



NORTHMASTER 760 CRUISER

---

# USER'S MANUAL

---





## INTRODUCTION

Thank you for purchasing Northmaster motorboat.

This manual has been created to help You use Your boat in a safe and pleasant way. It includes necessary information about Your boat and systems fitted to it as well as information about service and maintenance. Please read this manual thoroughly before using the boat.

If this is Your first boat or You don't feel confident enough to operate it, for Your own comfort and safety, get some handling and operating training first. You can contact Your nearest Northmaster dealer, he will be pleased to advise You.

PLEASE KEEP THIS MANUAL IN A SAFE PLACE AND IN CASE YOU SELL THE BOAT, PASS THE MANUAL TO IT'S NEW OWNER.

For further information about Your boat please visit our web page: [www.northmaster.eu](http://www.northmaster.eu)  
Online version of this Owner's Manual is also available there



**NORTHMASTER**



# INFORMATION ABOUT YOUR BOAT

## BUILDER'S PLATE & EXAMINATION REPORT

Builder's plate is mounted in the cockpit of Your boat.

1. CE mark and notified body's identification
2. Manufacture's name
3. Boat design category
4. Max. person capacity
5. Max. recommended power of engine
6. Max. recommended weight of engine
7. Max. recommended load (without weight of fluids in the tanks)
8. Boat's model

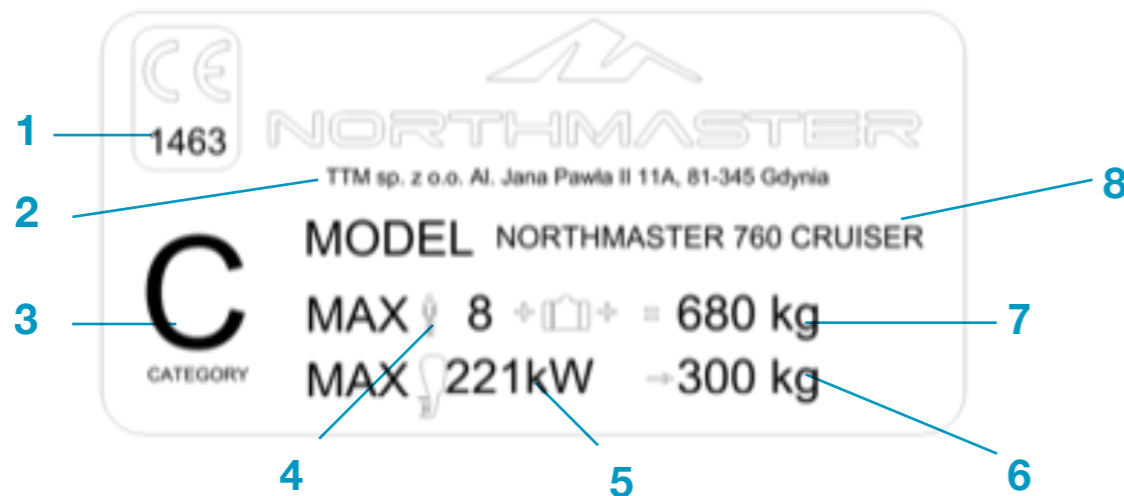

COPY



AC 114

### RAPORT Z BADAŃ (MODUŁ A1) EXAMINATION REPORT (MODULE A1)

Nr  
No. CW/RCD/30/04/2023

**ZAŚWIADCZA SIĘ,**  
że Polski Rejestr Statków S.A. (PRS) przeprowadził odpowiednią procedurę badania wymienionej niżej jednostki rekreacyjnej i stwierdził, że spełnia ona zasadnicze wymagania określone w załączniku I do dyrektywy 2013/53/UE (RCD), w następującym zakresie:

**THIS IS TO CERTIFY**  
that Polski Rejestr Statków S.A. (PRS) has undertaken the relevant examination procedure for the recreational craft identified below, which was found to meet the essential requirements of the Annex I to Directive 2013/53/EU (RCD), within the following scope:

A.3.2 Stateczność i wolna burta Stability and freeboard		A.3.3 Wyporność i pływalność Buoyancy and flotation	
Producent Manufacturer	TTM sp. z o. o., ul. Jana Pawła II 11A, 81-345 Gdynia, Poland		
Nazwa typu Brand name	<b>NORTHMASTER 760 CRUISER</b>	Rodzaj jednostki Type of craft	Łódź motorowa / motor boat
Kategoria projektowa Design category	C	Materiał kadłuba Material of hull	lps / GRP
Długość kadłuba Length of hull	7,35 m	Szerokość kadłuba Beam of hull	2,40 m
Maksymalna moc silnika(ów) Maximum engine(s) power	221,0 kW	Powierzchnia ozaglowania Sail area	— m <sup>2</sup>
Masa jednostki pustej wyposażonej Light craft condition mass	1650 kg	Maksymalna liczba osób Maximum number of persons	8
Maksymalna nośność Maximum load	1050 kg		

Informacje dodatkowe  
Other information

Masę jednostki pustej podano bez silnika przyczepnego.  
Dopuszczalna masa silnika przyczepnego - 300 kg.  
The light craft mass is given without an outboard engine.  
Permissible weight of outboard engine - 300 kg.

Badania jednostki przeprowadzono zgodnie z normą  
The examinations of the craft were carried out according to the standard EN ISO 12217-1:2017  
(PN-EN ISO 12217-1:2017-12)

Wyniki tych badań są opisane w sprawozdaniu nr  
The results of these examinations are described in the report No. KI/EM/37/23

Raport traci ważność po wprowadzeniu zmian w konstrukcji i wyposażeniu jednostki bez uprzedniego uzgodnienia z PRS.  
This report becomes invalid after modifications in construction or equipment of the craft without prior agreement with PRS.

Nr Rejestru PRS  
PRS Register No. 638272



*(Signature)*

Gdańsk, 2023-04-13

Dariusz Denis

**CE**  
Nr jednostki notyfikowanej  
No. of Notified Body  
**1463**

C/080/11  
Polski Rejestr Statków S.A.  
al. Gen. Józefa Hallera 126  
80-416 Gdańsk, Poland

Tel. (+48) 58 75 11 273  
Fax (+48) 58 34 17 769  
e-mail: dc@prs.pl  
www: http://www.prs.pl/

Form. 7A/PCW-01/RCD  
2020.06.08

1/1

## BASIC INFORMATION

1. MANUFACTURER:  
TTM Sp. Z o.o. Al. Jana Pawla II  
11a, 81-345 Gdynia, Poland
2. BOAT MODEL:  
760 Cruiser
3. LENGTH: 7,35m
4. WIDTH: 2,40m
5. MAX DRAFT: 0,44m
6. MAX. ENGINE POWER: 221kW
7. MAX ENGINE WEIGHT: 300kg
8. ENGINE SHAFT: XL
9. WEIGHT OF THE BOAT WITHOUT  
ENGINE: 1650kg
10. MAX. LOAD CAPACITY (including  
weight of fluids in the tanks): 1050kg
11. MAX. LOAD CAPACITY (without  
weight of fluid in the tanks): 680kg
12. MAX. PERSONS ON BOARD: 8
13. FUEL TANK CAPACITY: 250 litres

## BOAT'S LIMITATIONS

This boat has a design category C (ISO 12217-1) which means it is designed to be used on open inland waters, estuaries, coastal waters in moderate weather conditions.

Acceptable wind speed Beaufort is 6 B which is equivalent of 14 m/s. The max wave height is 2 meters.

Any boat, no matter how solid it is, may be severely damaged if not properly used. Thus always adjust the speed, trim and heading direction of the boat to the conditions on water.

Do not exceed the max number of people on board! The total weight of crew on board, the weight of additional equipment and crew's baggage cannot exceed the Max. load capacity of the boat.

When driving, make sure all of the passengers are using their sitting places. You should relocate passengers among the available seats to adjust the trim of the boat to the conditions on

water. Remember that standing in the cockpit changes the buoyancy of the boat.

Before driving the boat, all of the hatches, cabin doors, windscreen doors and inspection lids must be closed and locked if possible.

The maximum speed forward is 43 Knots and it must be reduced according to conditions on water

The maximum speed backwards is 3 Knots

# EQUIPMENT ON THE BOAT

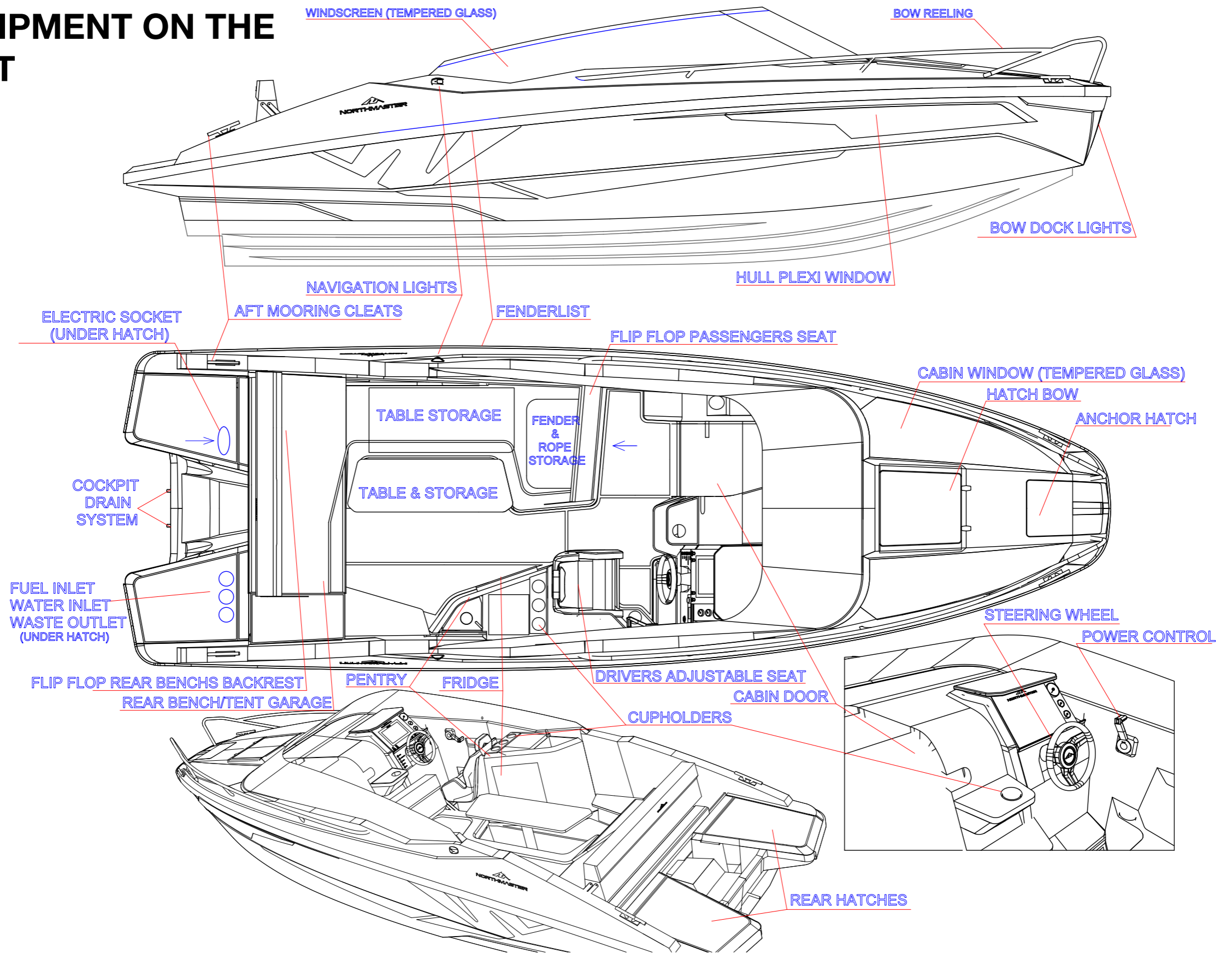

# FUEL SYSTEM

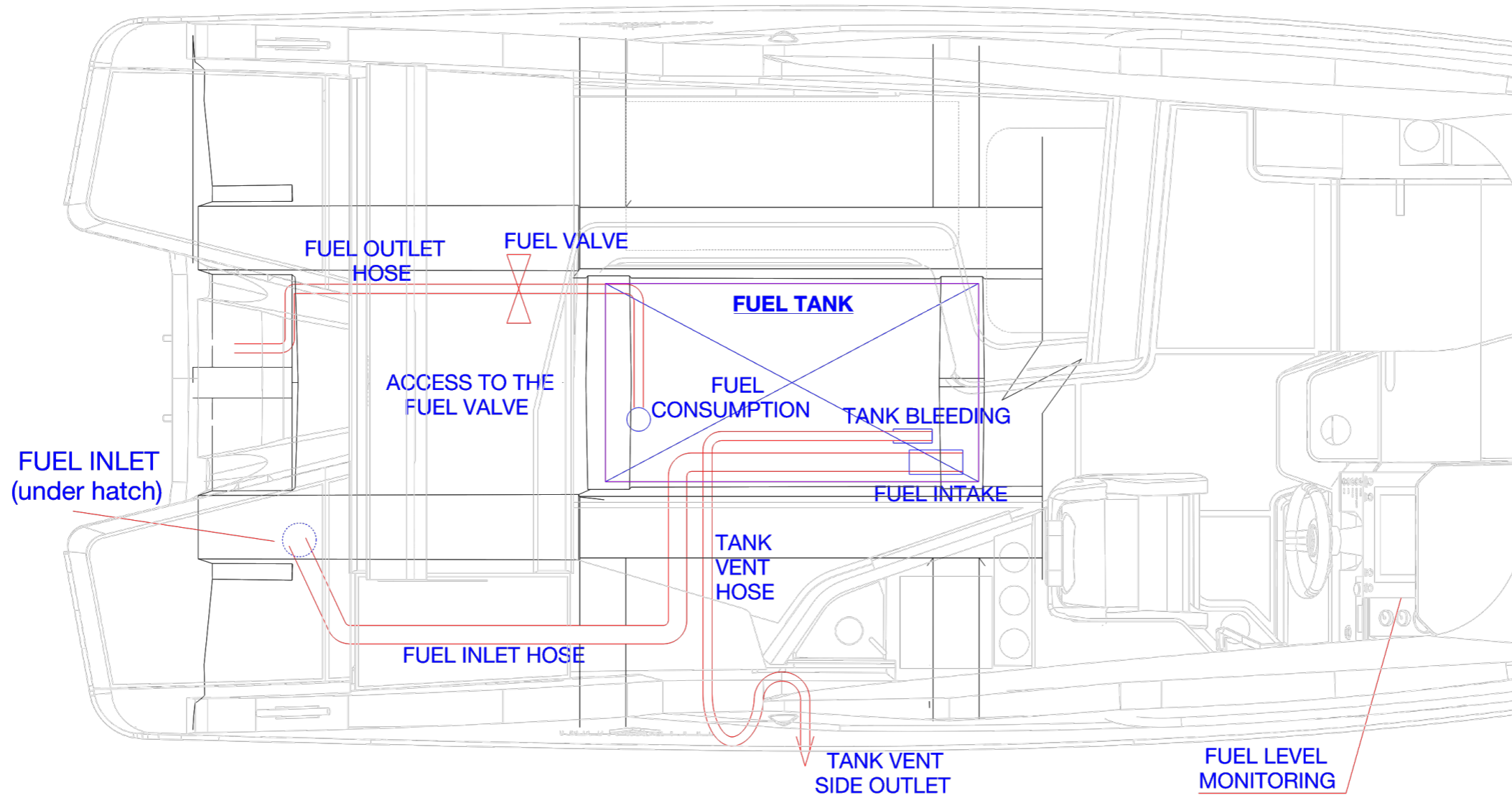

# ELECTRICAL INSTALLATION

PB - Battery powered fuse panel AKU (-) and AKU1  
 NAV-7,5 A (+12V) - U-com  
 TOP-7,5 A  
 Cabin light-7,5 A  
 Digital panel Q  
 Socket -10 A

+12V Bilge pump - 10A i Auto  
 Digital panel Q (AKU) 10 A  
 Macerator -10 A  
 Digital panel Q  
 Bow lights -15 A  
 Wipers -10 A  
 Ground (-)

Digital panel  
 Northmaster Infotainment  
 Cockpit lights - 10 A  
 Freeze - 10 A  
 Water pump - 10 A  
 Radio  
 Engine alarm  
 Bilge pump alarm  
 Fuel sensor

NI - digital panel

Connector	mppt	length	colour	from	to	destination
uninsulated	1x1	9,6	red	Q	R	digital panel
uninsulated	1x1	9,6	black	Q	R	digital panel
uninsulated	1x1,5	2,8	green	Q	E1	cockpit lighting
uninsulated	1x2,5	5,5	white-brown	Q	Y	water pump
uninsulated	1x2,5	5,2	red	Q	E	MNEA AKU
uninsulated	2x1	2,7	speaker red-black	Q	D1	right speaker

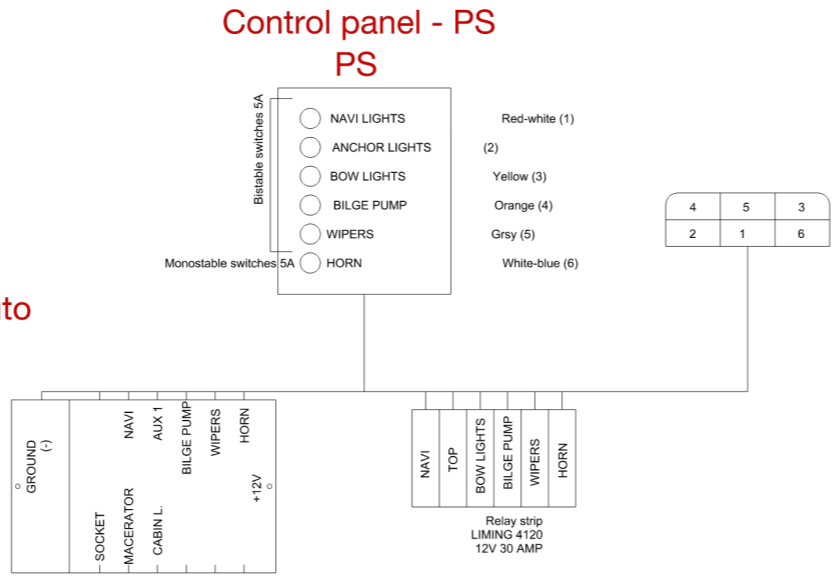

## 230 V installation

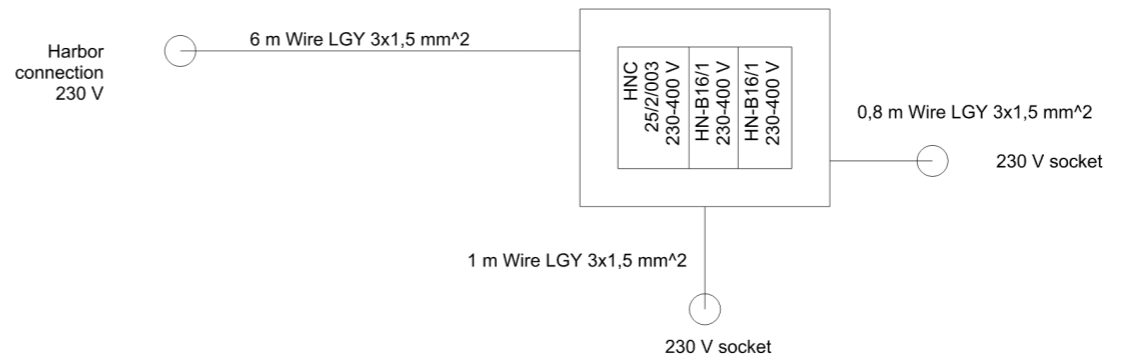

## 12 V charging instalation

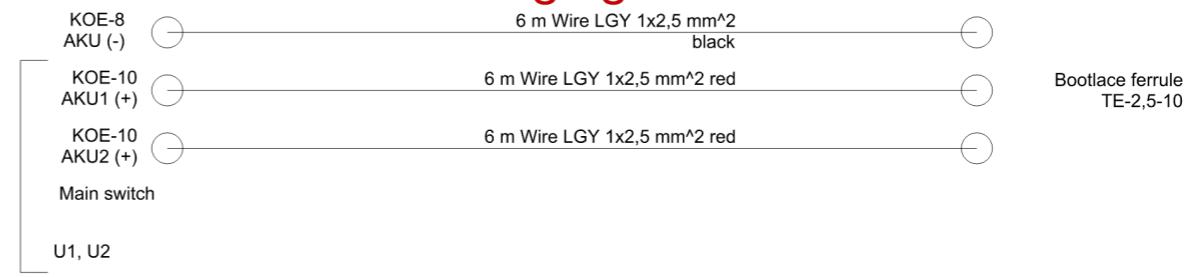

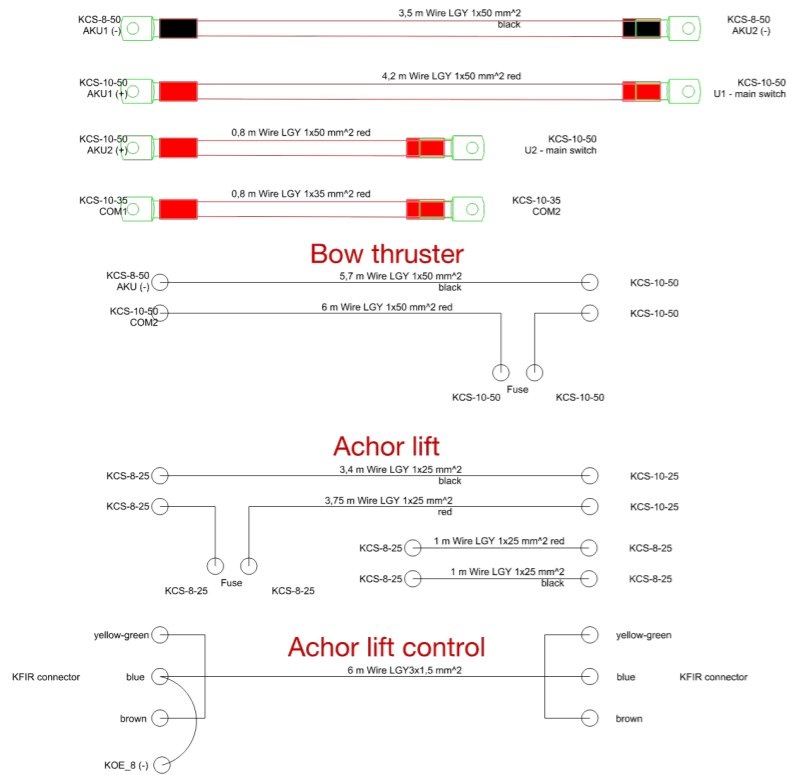

**PB**

Connector	mm <sup>2</sup>	length	colour	from	to	destination
uninsulated	1x1,5	8,1	black	PB	O	TOP
uninsulated	1x1,5	8,3	black	PB	N	NAVI
uninsulated	1x1,5	3	black	PB	E1	cockpit lighting
uninsulated	1x6	6,1	red	PB	U	U-com
uninsulated	1x2,5	7,2	black	PB	M	bilge pump
uninsulated	1x2,5	5,7	black	PB	Y	digital panel
cube 2 pin	1x2,5	4,8	red	PB	C1	microrator switch
cube 2 pin	1x2,5	5,2	black	PB	Z	microrator
uninsulated	1x1,5	6,4	yellow-green	PB	K	fuel tank ground
uninsulated	1x1,5	5,8	yellow-green	PB	K	fuel filler ground
cube 2 pin	1x2,5	7	black	PB	H	fridge
uninsulated	1x1,5	7,1	black	PB	G	NAVI
uninsulated	1x6	5,9	black	PB	F	ground shu
uninsulated	1x1,5	2,6	red	PB	F1	microrator sensor
uninsulated	1x1,5	2,6	black	PB	F1	microrator sensor
uninsulated	1x1,5	2,8	black	PB	H1	Cab light LED
uninsulated	1x1,5	2,4	green	PB	A	Cab light switch
uninsulated	1x2,5	6,8	black	PB	H1	bow lights
cube 3 pin	1x1,5	3,3	red	PB	C	wiper
cube 3 pin	1x1,5	3,3	black	PB	C	wiper
uninsulated	1x1,5	3,3	green	PB	B	Cab light
uninsulated	1x1,5	3,3	black	PB	B	Cab light
uninsulated	1x2,5	2,2	red	PB	K1	socket
uninsulated	1x2,5	2,2	black	PB	K1	socket

Connector	mm <sup>2</sup>	length	colour	from	to	destination
Cube 6 pin	1x1,5	7,9	white-red	PS	O	TOP
Cube 6 pin	1x1,5	8,15	white-red	PS	N	NAVI
uninsulated	1x2,5	7	orange	PS	M	bilge pump
uninsulated	1x1,5	6,9	white-red	PS	G	NAVI
uninsulated	1x2,5	6,7	yellow	PS	H1	bow lights
cube 3 pin	1x1,5	3,4	grey	PS	C	wiper

Connector	mm <sup>2</sup>	length	colour	from	to	destination
uninsulated	1x1,5	3,3	green	B	PB	fuse panel
uninsulated	1x1,5	3,3	black	B	PB	fuse panel

**Q3 Fuel sensor**

Connector	mm <sup>2</sup>	length	colour	from	to	destination
hermetic Euro 2 pin	1x1,5	6,2	brown-white	J	Q3	fuel sensor
hermetic Euro 2 pin	1x1,5	6,2	black	J	Q3	fuel sensor

**Q5 Bilge pump alarm**

Connector	mm <sup>2</sup>	length	colour	from	to	destination
cube 2 pin	1x1,5	4,9	blue	Q5	A1	bilge pump alarm
cube 2 pin	1x1,5	4,9	red	Q5	A1	bilge pump alarm

**Cockpit lighting, fridge, water pump**

Connector	mm <sup>2</sup>	length	colour	from	to	destination
cube 2 pin	1x2,5	6,8	white-blue	Q2	H	fridge

**Power supply NMEA Northmaster Infotainment**

**Q6 Engine alarm**

Connector	mm <sup>2</sup>	length	colour	from	to	destination
cube 2 pin	1x1,5	4,9	blue	Q6	A1	engine theft alarm
cube 2 pin	1x1,5	4,9	brown-white	Q6	A1	engine theft alarm

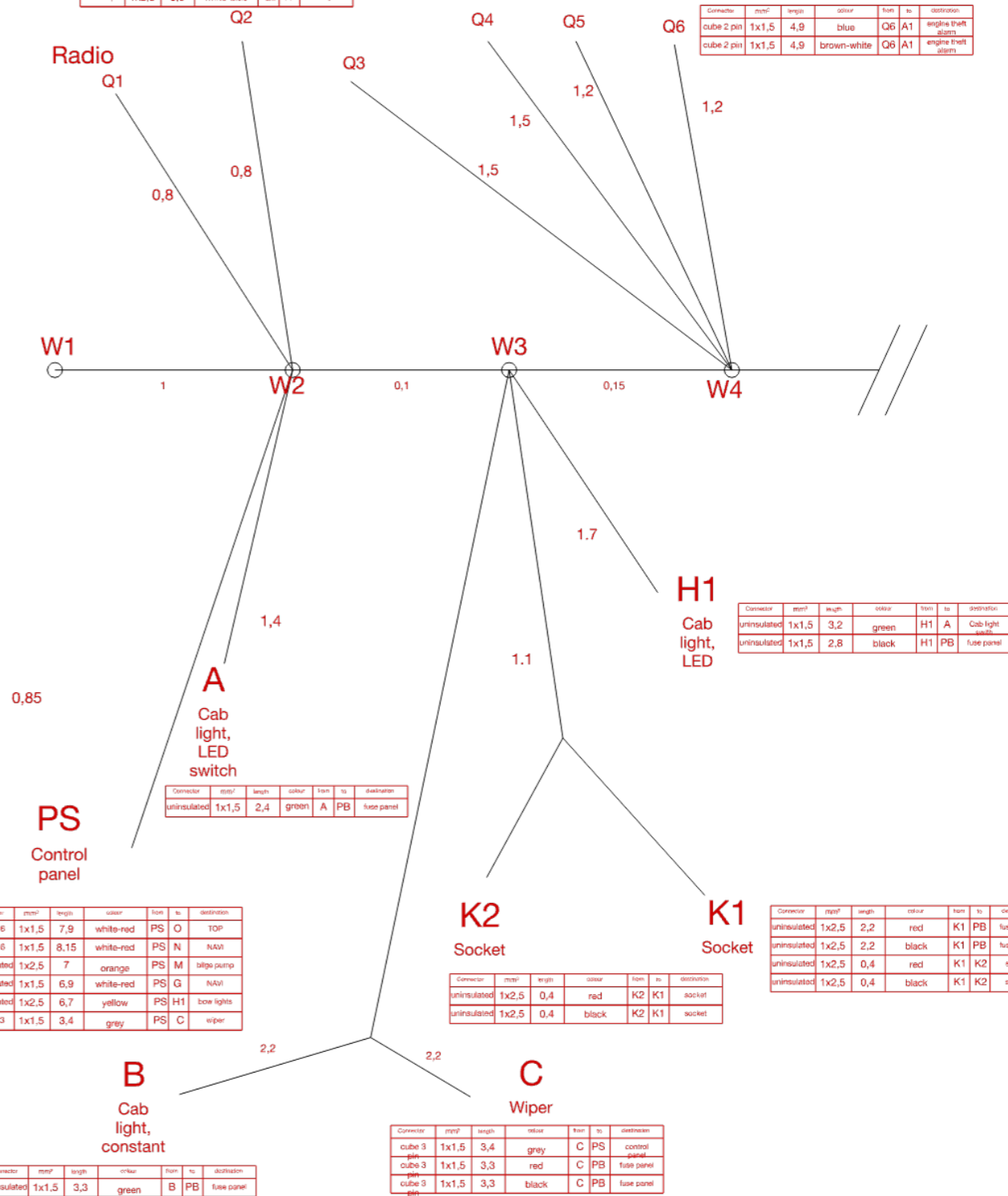

Connector	mm <sup>2</sup>	length	colour	from	to	destination
uninsulated	1x1,5	3,2	green	H1	A	Cab light switch
uninsulated	1x1,5	2,8	black	H1	PB	fuse panel

Connector	mm <sup>2</sup>	length	colour	from	to	destination
uninsulated	1x2,5	2,2	red	K1	PB	fuse panel
uninsulated	1x2,5	2,2	black	K1	PB	fuse panel
uninsulated	1x2,5	0,4	red	K1	K2	socket
uninsulated	1x2,5	0,4	black	K1	K2	socket

Connector	mm <sup>2</sup>	length	colour	from	to	destination
uninsulated	1x2,5	0,4	red	K2	K1	socket
uninsulated	1x2,5	0,4	black	K2	K1	socket

Connector	mm <sup>2</sup>	length	colour	from	to	destination
cube 3 pin	1x1,5	3,4	grey	C	PS	control panel
cube 3 pin	1x1,5	3,3	red	C	PB	fuse panel
cube 3 pin	1x1,5	3,3	black	C	PB	fuse panel



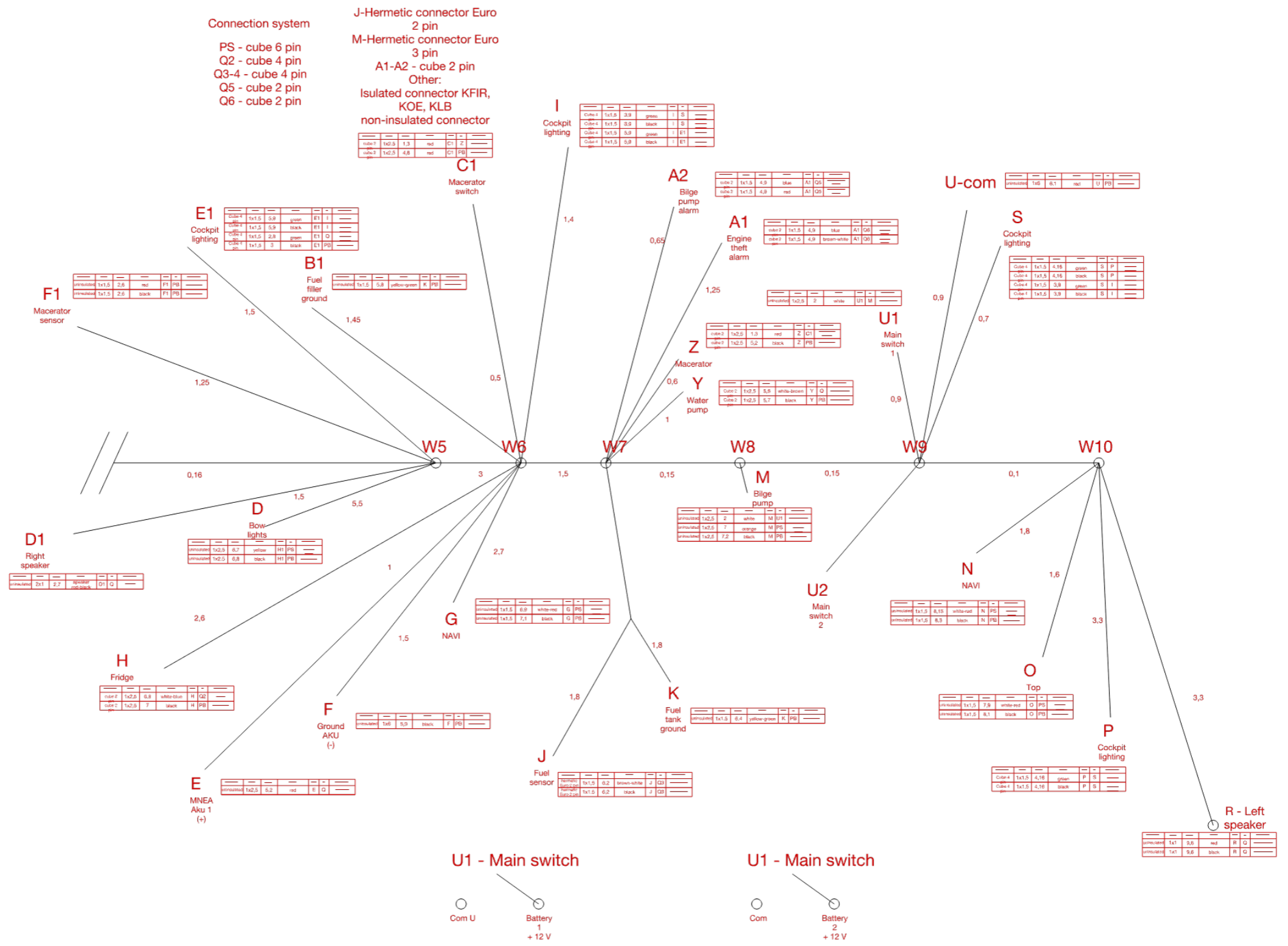

# OPERATING THE BOAT

## BEFORE YOU CRUISE

Check water level in the bilge. If necessary remove the water using bilge pump.

Check whether the bilge pumps are working.

If your boat is equipped with water toilet, make sure the valve for waste disposal thru the hull is closed.

Check the battery charge status

Periodically check the conditions and installation of clamps on the battery.

## CRUISING

Cruising speed must be adjusted to the current conditions on the water

All crew members should wear life jackets

All crew members should seat on the designated seats on the boat. Nobody should stand while the boat is being operated.

None of the crew member should remain in the cabin compartment while the boat is being navigated. Cabin doors should be closed.

If the boat is permitted to be used during the night time, remember to turn navigation lights on.

Max speed forward is 36 Knots

Max speed backwards is 3 Knots

Max speed forward with unfolded tent is 18 Knots.

## MOORING & TOWING

It is hellman's duty to check the condition of mooring ropes, tow ropes, fender ropes and anchor rope.

Mooring ropes should be adjusted to the boat

Towing maneuvers should be always held at low speed

The towing rope should be attached to the boat in the way, that it can be easily released under load's pressure.

The boat is not suitable to be used in the winter period, especially in solid or crushed ice and when boat is covered with ice.

Do not do the circulation when the fuel tank level is less than 25%, when crew members are seating on the side of the boat, causing it to trim on that side, nor when the speed of the boat is too high.

A rotating propeller can cause death or permanent disability therefore if one of the crew member is overboard, immediately turn off the engine (Except for rescue actions, than proceed with rescue maneuvers with the greatest attention and turn off the engine while taking man from the water.



# **MAINTAINANCE AND SERVICE**

## **HULL & DECK**

Several elements of the boat are made of glass reinforced polyester with gelcoat external surface, this includes the hull and the deck. Regular cleaning gives Your boat a better look. Do not use abrasive scratching chemicals, solvents, ammonia, chlorine, acetone and ketone-based solvents as they can damage the surface of the gelcoat.

In the cold period, the deck of the boat must be protected against snow and ice. Make sure to dry the surface of the deck properly before applying a cover.

After taking the boat out of water it's hull should be cleaned. If using a pressurized water, remember to keep the distance between the water jet and the surface of the hull. Using too much pressure or keeping too small distance might cause destruction of gelcoat layer.

## **COCKPIT**

Remember to protect you cockpit against sun exposure and rain water. There are several fabrics and materials in the cockpit that might be sensitive to exceeded sunlight I.e. mattresses, floor panels, leather fabric on the steering wheel or the wooden elements. When leaving the boat, always put on a cockpit cover or a tent.

## **STAINLESS STEEL**

Polished stainless steel is resistant to corrosion, however it has to be kept in good condition. Remember to clean the steel elements with fresh water after every use on salt water or polluted water.

Occasionally slight signs of corrosion on the stainless steel might occur, which is not the result of defective material, rather lack of proper maintenance.

## **PLEXI**

Use warm water and detergents to clean plexi elements. Do not use strong and abrasive liquids such as acetone or gasoline as it will permanently tarnish and damage the surface.

## **SERVICE**

Check the condition of anodes regularly. Change anodes for a new ones when the state of corrosion exceeds 40%.

It is forbidden to drill any holes in the construction elements of the boat (hull, deck, GRP elements). Only authorized service can do any changes on Your boat.

All repairs and services of Your boat shall be carried out by an authorized service

## WINTER STORAGE

Before you put Your Northmaster for winter storage, there are several things You need to do on the boat. You can always use authorized service, which will prepare the boat for winter for You.

1. clean the boat outside with fresh water and proper detergents and dry it
2. Dry the boat inside, if necessary take out the water from the bilge
3. Remove mattresses from the boat
4. Check whether electronic devices installed on the boat is freeze-proof
5. Secure water and waste installation against freezing. You can either empty the tanks and remove the water from pipes and pumps by air compressor or fill it with freeze-proof fluids.
6. Lubricate all elastic seals on the boat I.e. with gliceryne
7. Cabin doors, hatches and doors should be open so that the interior is well ventilated
8. Disassemble the battery and store in a dry and warm place. Provide charging and battery service in the winter period
9. Make sure the boat is well ventilated under the winter cover. If the boat is wrapped in plastic, make sure there at least 2 ventilation holes. You should later inspect the ventilation holes to make sure that snow or ice has not blocked the air.
10. Check whether the material used for covering the boat is not too loose and whether it is well supported. Inspect the boat in the winter period and take away the snow, ice or water laying on the cover fabric. If it is supported only by the boat's elements such as windscreen or reelings, it might get destroyed due to heavy weight of snow, ice or water.
11. Fill the fuel tank with fuel.

12. Make sure the hull of the boat is well supported on a trailer or cradle. The hull has to be supported along the keel and there should be additional supports on the side. Make sure the hull is not being bended in any support area.

## CARRYING ON A TRAILER

Use only special boat trailer to carry Your boat. The weight of the boat, engine and additional accessories cannot exceed the max trailer load. It is important that the length of the hull does not exceed the trailer length.

Make sure the hull is well supported on the keep. Supports on the side are only used to position the boat, not to carry it's weight. If the hull is not supported along the keel, it might be destroyed when stored or towed on a trailer

When taking the boat out of water on a trailer alway use the hull's mooring eye on the bow. Beware that when towing the boat upwards, the stern of the boat will seat on a trailer and the bow



might raise significantly. If the front towing strap is too tightened it might destroy the mooring eye on the hull.