



NORTHMASTER 585 OPEN

USER'S MANUAL



INTRODUCTION

Thank you for purchasing Northmaster motorboat.

This manual has been created to help You use Your boat in a safe and pleasant way. It includes necessary information about Your boat and systems fitted to it as well as information about service and maintenance. Please read this manual thoroughly before using the boat.

If this is Your first boat or You don't feel confident enough to operate it, for Your own comfort and safety, get some handling and operating training first. You can contact Your nearest Northmaster dealer, he will be pleased to advise You.

PLEASE KEEP THIS MANUAL IN A SAFE PLACE AND IN CASE YOU SELL THE BOAT, PASS THE MANUAL TO IT'S NEW OWNER.

For further information about Your boat please visit our web page: www.northmaster.eu
Online version of this Owner's Manual is also available there



NORTHMASTER

INFORMATION ABOUT YOUR BOAT

BUILDER'S PLATE

Builder's plate is mounted in the cockpit of Your boat.

1. CE mark and notified body's identification
2. Manufacture's name
3. Boat design category
4. Max. person capacity
5. Max. recommended power of engine
6. Max. recommended weight of engine
7. Max. recommended load without fluids in the tanks
8. Boat's model

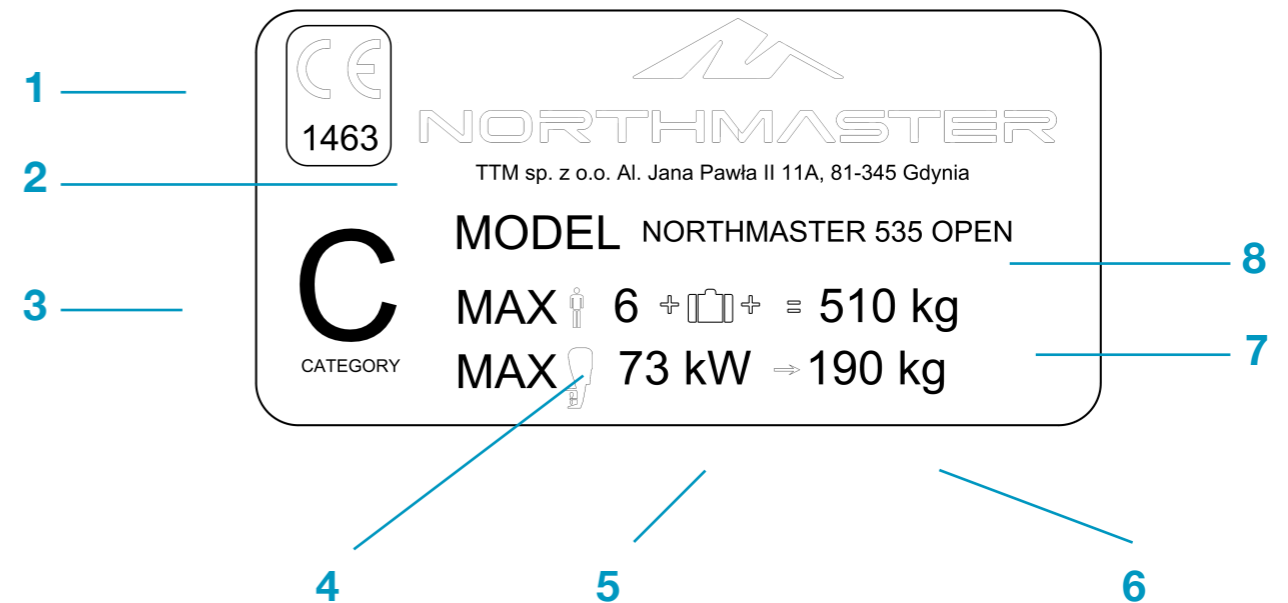

BASIC INFORMATION

1. MANUFACTURER:
TTM Sp. Z o.o. Al. Jana Pawla II 11a,
81-345 Gdynia, Poland
2. BOAT MODEL:
535 Open
3. LENGTH: 5,35m
4. WIDTH: 2,14m
5. DRAFT: 0,27m
6. MAX. ENGINE POWER: 100 HP
7. MAX ENGINE WEIGHT: 190kg
8. WEIGHT OF THE BOAT WITHOUT
ENGINE: 700kg
9. MAX. LOAD CAPACITY (without fluids
in the tanks): 510kg
10. MAX. LOAD CAPACITY (including
fluids in the tanks): 570kg
11. MAX. PERSONS ON BOARD: 6

12. FUEL TANK CAPACITY: 60 litres

BOAT'S LIMITATIONS

This boat has a design category C (ISO 12217-1) which means it is designed to be used on open inland waters, estuaries, coastal waters in moderate weather conditions.

Acceptable wind speed Beaufort is 6 B which is equivalent of 14 m/s. The max wave height is 2 meters.

Any boat, no matter how solid it is, may be severely damaged if not properly used. Thus always adjust the speed, trim and heading direction of the boat to the conditions on water.

Do not exceed the max number of people on board! The total weight of crew on board, the weight of additional equipment and crew's baggage cannot exceed the Max. load capacity of the boat.

When driving, make sure all of the passengers are using their sitting places. You should relocate passengers among the available seats to adjust the trim of the

boat to the conditions on water. Remember that standing in the cockpit changes the buoyancy of the boat.

Before driving the boat, all of the hatches and inspection lids must be closed and locked if possible.

The maximum speed forward is 28 Knots and it must be reduced according to conditions on water

The maximum speed backwards is 3 Knots

BOAT'S EQUIPMENT

1. Water drain system
2. Inspection hatch
3. Aft bench
4. driver's bench
5. Sunbed
6. anchor's hatch
7. bow's cleats
8. Anchor light
9. Aft cleats
10. Grab rails
11. Navigation lights
12. Windscreen with stainless reeling
13. bow's reeling
14. Ski hook
15. Dashboard

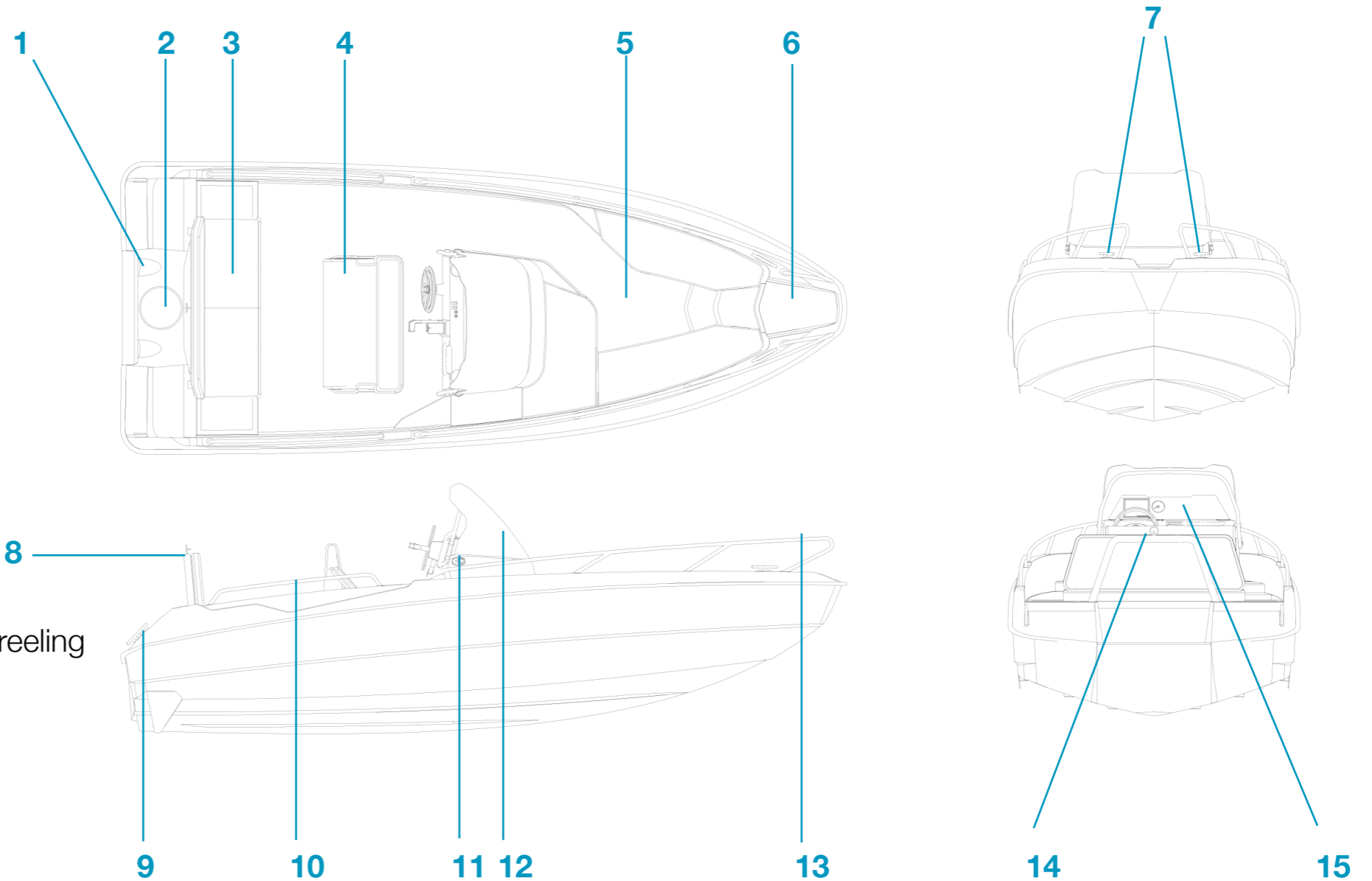

FUEL SYSTEM

1. Fuel inlet
2. Fuel gauge inspection (under the aft bench)
3. Fuel tank
4. Fuel tank inspection (under the driver's bench)

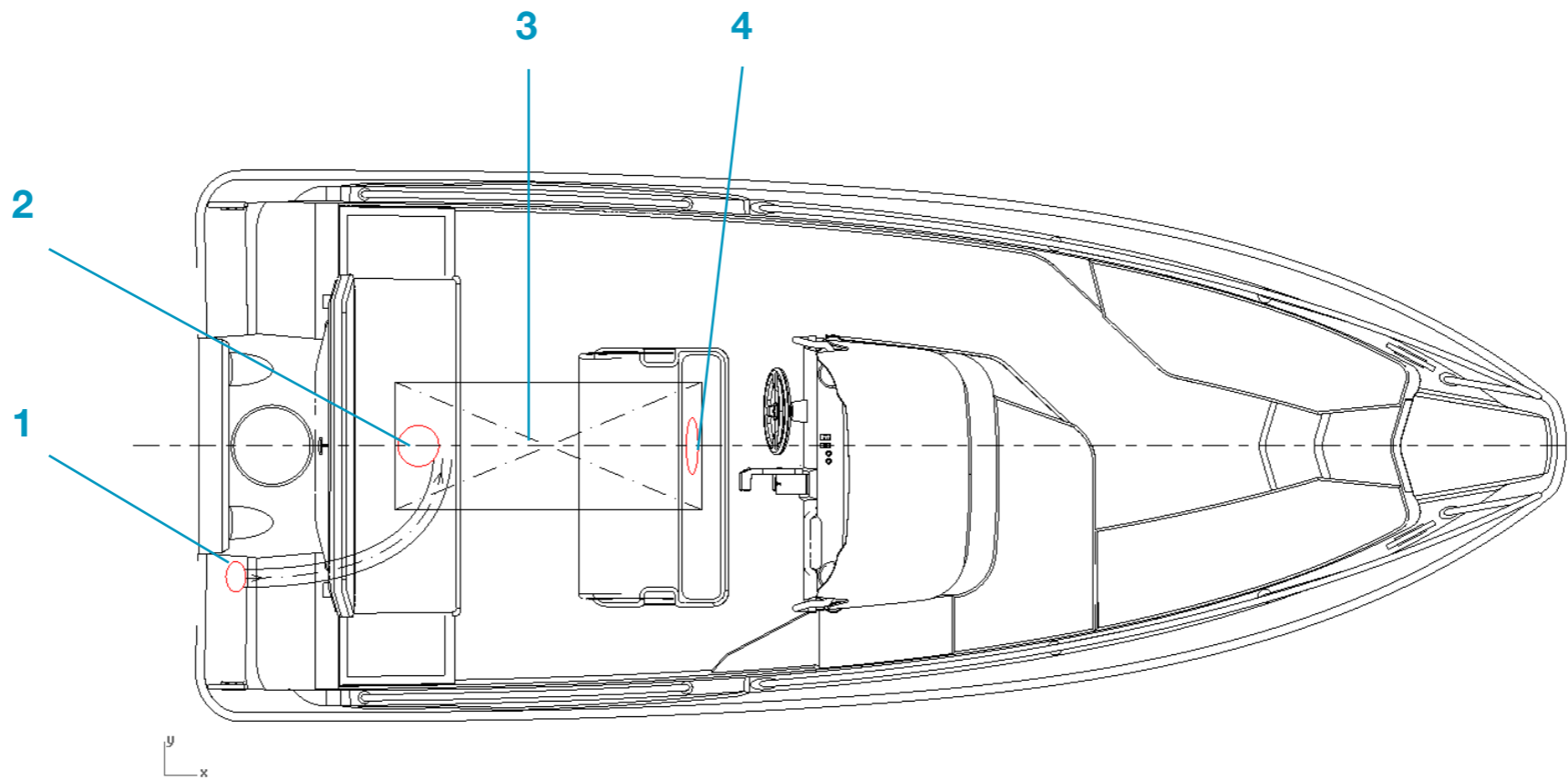

ELECTRICAL INSTALLATION

Wersja	Uwagi	Data	Podpis	Sprawdzit

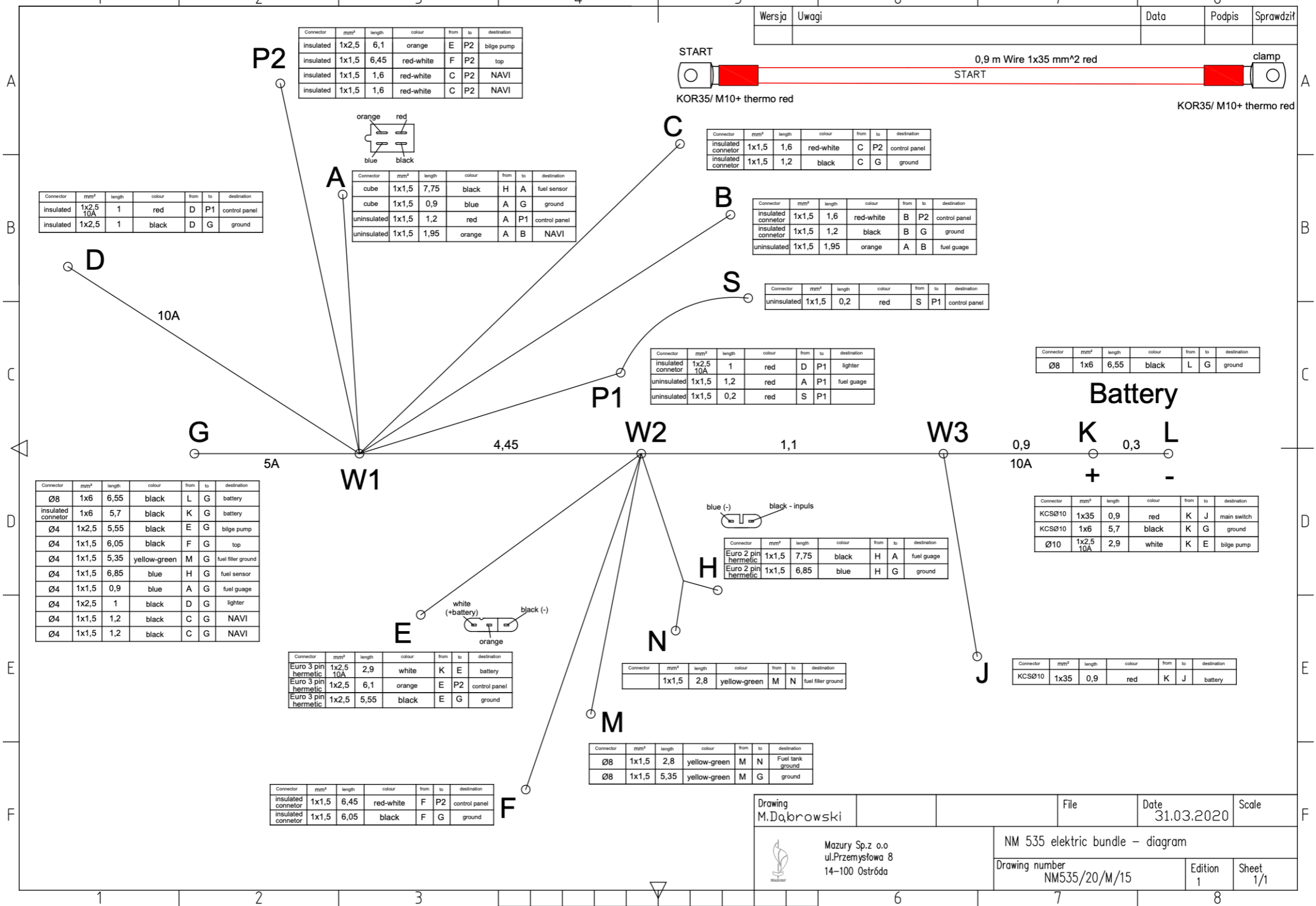

Connector	mm ²	length	colour	from	to	destination
insulated	1x2,5	6,1	orange	E	P2	bilge pump
insulated	1x1,5	6,45	red-white	F	P2	top
insulated	1x1,5	1,6	red-white	C	P2	NAVI
insulated	1x1,5	1,6	red-white	C	P2	NAVI

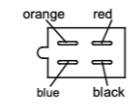

Connector	mm ²	length	colour	from	to	destination
cube	1x1,5	7,75	black	H	A	fuel sensor
cube	1x1,5	0,9	blue	A	G	ground
uninsulated	1x1,5	1,2	red	A	P1	control panel
uninsulated	1x1,5	1,95	orange	A	B	NAVI

Connector	mm ²	length	colour	from	to	destination
insulated	1x2,5	1	red	D	P1	control panel
insulated	1x2,5	1	black	D	G	ground

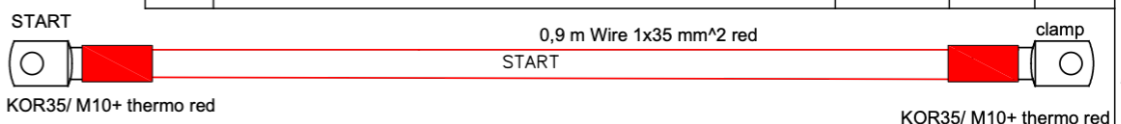

Connector	mm ²	length	colour	from	to	destination
insulated connetor	1x1,5	1,6	red-white	C	P2	control panel
insulated connetor	1x1,5	1,2	black	C	G	ground

Connector	mm ²	length	colour	from	to	destination
insulated connetor	1x1,5	1,6	red-white	B	P2	control panel
insulated connetor	1x1,5	1,2	black	B	G	ground
uninsulated	1x1,5	1,95	orange	A	B	fuel guage

Connector	mm ²	length	colour	from	to	destination
uninsulated	1x1,5	0,2	red	S	P1	control panel

Connector	mm ²	length	colour	from	to	destination
insulated connetor	1x2,5	1	red	D	P1	lighter
uninsulated	1x1,5	1,2	red	A	P1	fuel guage
uninsulated	1x1,5	0,2	red	S	P1	

Connector	mm ²	length	colour	from	to	destination
Ø8	1x6	6,55	black	L	G	ground

Battery

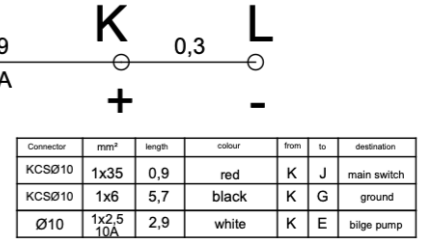

Connector	mm ²	length	colour	from	to	destination
KCSØ10	1x35	0,9	red	K	J	main switch
KCSØ10	1x6	5,7	black	K	G	ground
Ø10	1x2,5	2,9	white	K	E	bilge pump

Connector	mm ²	length	colour	from	to	destination
Ø8	1x6	6,55	black	L	G	battery
insulated connetor	1x6	5,7	black	K	G	battery
Ø4	1x2,5	5,55	black	E	G	bilge pump
Ø4	1x1,5	6,05	black	F	G	top
Ø4	1x1,5	5,35	yellow-green	M	G	fuel filler ground
Ø4	1x1,5	6,85	blue	H	G	fuel sensor
Ø4	1x1,5	0,9	blue	A	G	fuel guage
Ø4	1x2,5	1	black	D	G	lighter
Ø4	1x1,5	1,2	black	C	G	NAVI
Ø4	1x1,5	1,2	black	C	G	NAVI

Connector	mm ²	length	colour	from	to	destination
Euro 3 pin hermetic	1x2,5	2,9	white	K	E	battery
Euro 3 pin hermetic	1x2,5	6,1	orange	E	P2	control panel
Euro 3 pin hermetic	1x2,5	5,55	black	E	G	ground

Connector	mm ²	length	colour	from	to	destination
Euro 2 pin hermetic	1x1,5	7,75	black	H	A	fuel guage
Euro 2 pin hermetic	1x1,5	6,85	blue	H	G	ground

Connector	mm ²	length	colour	from	to	destination
Ø8	1x1,5	2,8	yellow-green	M	N	fuel filler ground

Connector	mm ²	length	colour	from	to	destination
Ø8	1x1,5	2,8	yellow-green	M	N	Fuel tank ground
Ø8	1x1,5	5,35	yellow-green	M	G	ground

Connector	mm ²	length	colour	from	to	destination
insulated connetor	1x1,5	6,45	red-white	F	P2	control panel
insulated connetor	1x1,5	6,05	black	F	G	ground

Drawing M.Dąbrowski	File	Date 31.03.2020	Scale
Mazury Sp.z o.o ul.Przemysłowa 8 14-100 Ostróda	NM 535 elektric bundle – diagram		
Drawing number NM535/20/M/15	Edition 1	Sheet 1/1	

OPERATING THE BOAT

BEFORE YOU CRUISE

Check water level in the bilge. If necessary remove the water using bilge pump.

Check whether the bilge pumps are working.

Check the battery charge status

Periodically check the conditions and installation of clamps on the battery.

CRUISING

Cruising speed must be adjusted to the current conditions on the water

All crew members should wear life jackets

All crew members should seat on the designated seats on the boat. Nobody should stand while the boat is being operated.

If the boat is permitted to be used during the night time, remember to turn navigation lights on.

Max speed forward is 28 Knots

Max speed backwards is 3 Knots

MOORING & TOWING

It is hellman's duty to check the condition of mooring ropes, tow ropes, fender ropes and anchor rope.

Mooring ropes should be adjusted to the boat

Towing maneuvers should be always held at low speed

The towing rope should be attached to the boat in the way, that it can be easily released under load's pressure.

The boat is not suitable to be used in the winter period, especially in solid or crushed ice and when boat is covered with ice.

Do not do the circulation when the fuel tank level is less than 25%, when crew members are seating on the side of the boat, causing it to trim on that side, nor when the speed of the boat is too high.

A rotating propeller can cause death or permanent disability therefore if one of the crew member is overboard, immediately turn off the engine (Except for rescue actions, than proceed with rescue maneuvers with the greatest attention and turn off the engine while taking man from the water.

MAINTAINANCE AND SERVICE

HULL & DECK

Several elements of the boat are made of glass reinforced polyester with gelcoat external surface, this includes the hull and the deck. Regular cleaning gives Your boat a better look. Do not use abrasive scratching chemicals, solvents, ammonia, chlorine, acetone and ketone-based solvents as they can damage the surface of the gelcoat.

In the cold period, the deck of the boat must be protected against snow and ice. Make sure to dry the surface of the deck properly before applying a cover.

After taking the boat out of water it's hull should be cleaned. If using a pressurized water, remember to keep the distance between the water jet and the surface of the hull. Using too much pressure or keeping too small distance might cause destruction of gelcoat layer.

COCKPIT

Remember to protect you cockpit against sun exposure and rain water. There are several fabrics and materials in the cockpit that might be sensitive to exceeded sunlight I.e. mattresses, floor panels, leather fabric on the steering wheel or the wooden elements. When leaving the boat, always put on a console cover.

STAINLESS STEEL

Polished stainless steel is resistant to corrosion, however it has to be kept in good condition. Remember to clean the steel elements with fresh water after every use on salt water or polluted water.

Occasionally slight signs of corrosion on the stainless steel might occur, which is not the result of defective material, rather lack of proper maintenance.

PLEXI

Use warm water and detergents to clean plexi elements. Do not use strong and

abrasive liquids such as acetone or gasoline as it will permanently tarnish and damage the surface.

SERVICE

Check the condition of anodes regularly. Change anodes for a new ones when the state of corrosion exceeds 40%.

It is forbidden to drill any holes in the construction elements of the boat (hull, deck, GRP elements). Only authorized service can do any changes on Your boat.

All repairs and services of Your boat shall be carried out by an authorized service

WINTER STORAGE

Before you put Your Northmaster for winter storage, there are several things You need to do on the boat. You can always use authorized service, which will prepare the boat for winter for You.

1. clean the boat outside with fresh water and proper detergents and dry it
2. Dry the boat inside, if necessary take out the water from the bilge
3. Remove mattresses from the boat
4. Check whether electronic devices installed on the boat is freeze-proof
5. Lubricate all elastic seals on the boat l.e. with gliceryne
6. Hatches should remain open so that it is properly ventilated
7. Disassemble the battery and store in a dry and warm place. Provide charging and battery service in the winter period
8. Make sure the boat is well ventilated under the winter cover. If the boat is wrapped in plastic, make sure there at least 2 ventilation holes. You should later inspect the ventilation holes to make sure that snow or ice has not blocked the air.
9. Check whether the material used for covering the boat is not too loose and whether it is well supported. Inspect the boat in the winter period and take away the snow, ice or water laying on the cover fabric. If it is supported only by the boat's elements such as windscreen or reelings, it might get destroyed due to heavy weight of snow, ice or water.
10. Fill the fuel tank with fuel.
11. Make sure the hull of the boat is well supported on a trailer or cradle. The hull has to be supported along the keel and there should be additional supports on the side. Make sure the hull is not being bended in any support area.

CARRYING ON A TRAILER

Use only special boat trailer to carry Your boat. The weight of the boat, engine and additional accessories cannot exceed the max trailer load. It is important that the length of the hull does not exceed the trailer length.

Make sure the hull is well supported on the keep. Supports on the side are only used to position the boat, not to carry it's weight. If the hull is not supported along the keel, it might be destroyed when stored or towed on a trailer

When taking the boat out of water on a trailer always use the hull's mooring eye on the bow. Beware that when towing the boat upwards, the stern of the boat will seat on a trailer and the bow might raise significantly. If the front towing strap is too tightened it might destroy the mooring eye on the hull.